



# **morsø**

By appointment to the Royal Danish Court

## **Installation and Operating Instructions**

### **3600 series**

**For use in North America**



**Read this entire manual before you install and use your new room heater. If this room heater is not properly installed, a house fire may result. To reduce the risk of fire, follow the installation instructions. Failure to follow instructions may result in property damage, bodily injury, or even death.**

**Contact local building officials about restrictions and installation/inspection-requirements in your area.**

**Save these instructions**

**MORSØ JERNSTØBERI A/S . DK-7900 NYKØBING MORS  
E-Mail: [stoves@morsoe.com](mailto:stoves@morsoe.com) · Website: [www.morsoe.com](http://www.morsoe.com)**

**Distributed by: MORSO US LLC  
1011 Highway 52 West - Portland TN - 37148 - USA**

**We congratulate you on your choice of a Morsø stove. Morsø has been producing some of the world's best stoves since 1853. If you follow this installation- and operating instruction carefully, we can assure you many years of warmth and pleasure.**

**Optional Accessories**

A wide range of accessories (such as handling gloves, fireside tools, glass cleaner and heatproof paint) are available for use with your Morsø stove. They help with day-to-day running and maintenance. Contact your Morsø dealer for more information.

The Morsø 3600 meets the U.S. Environmental Protection Agency's emission limits for wood heaters sold on or after July 1, 1990



The Morsø 3600 are listed by OMNI-Test Laboratories, Inc. The test standards are ANSI/UL-1482 for the United States and ULC S627 for Canada.

**The stove is listed for burning wood only. Do not burn other fuels.**

Under specific test conditions this heater has been shown to deliver heat at rates ranging from 11,400 to 49,500 Btu's.

**Cast iron**

Cast iron is a live material. There are no two ovens that are identical. This is partly due to the tolerances of the casting process, partly because the ovens are a work of craftsmanship.

## **CONTENTS:**

<b>1.0</b>	<b>Installation of your Morsø stove</b>	<b>4</b>
1.1	Unpacking the stove	4
1.2	Checking loose parts in the stove	4
1.3	The chimney / flue system	5
1.4	Flue Connection	6
1.5	Connection to existing chimney	6
1.6	Positioning the stove	8
<b>2.0</b>	<b>Operation</b>	<b>11</b>
2.1	Before you start firing	11
2.2	Lighting and loading intervals	12
<b>3.0</b>	<b>Maintenance</b>	<b>14</b>
3.1	Exterior maintenance	14
3.2	Internal maintenance	14
3.3	Cleaning the Stove and the Flue	16
3.4	Leaving the stove for extended periods	17
3.5	Parts diagram	18
3.6	Parts list	19

## 1.0 Installation of your Morsø stove

**Installation of woodburning stoves must be safe and legal.**

**If your Morsø stove is not installed correctly, it may cause a house fire. To reduce the risk of fire, the installation instructions must be followed carefully. Contact the local building officials about restrictions and installation inspection in your area.**

Before you start installing your stove, make sure that:

- The stove and chimney connection are placed far enough from combustible materials to meet all clearance requirements.
- The floor protection must be adequate and must be made correctly according to the requirements.

All necessary approvals are needed from the local building officials.

The data plate, which is located on the back of the stove, provides information regarding safety testing information, name of certified testing laboratory, and installation requirements.

Installation requirements vary in different districts, and the local building officials have the final authorization to approve your installation. You should discuss the installation with them before beginning. Please ask your dealer for further information.

**Do not connect to any air distribution duct or system.**

**Important: If the installation instructions are not followed carefully, it may cause dangerous situations like chimney - and house fires. Follow the instructions carefully and do not deviate from them as it may cause injuries to people or property.**

### 1.1 Unpacking the stove

After removing the outer packaging, flatten it and lay onto the floor close to the stove; this can then act as protective work surface during the assembly process.

Next, remove the legs and bolts from inside the stove. Gently lay the stove onto its back. Using the bolts supplied, now screw the legs into position on the underside of the base. The stove should now be lifted and moved into the upright position, avoiding excess load on the back legs.

The stove is heavy and therefore it is strongly recommended that when lifting, it is undertaken by two people. Morsø 3610 weighs 199 kg. Morsø 3640 weighs 209 kg.

### 1.2 Checking loose parts in the stove

After unpacking, check that the fire bricks are firmly in position and have not shifted in transit. Check also that the air control works freely.

#### **Standard Accessories**

Poker, ceramic flue connection gasket and ash pan tools are standard accessories, and can usually be found in the ashpan or firebox area.

### 1.3 The chimney / flue system

Note that the flue system must be independently secured and must not rely on the stove for support.

**The stove must not be connected to a chimney flue serving any other appliance. (Several flues may run up a single chimney stack; use one flueway per appliance).**

**Use a residential type masonry or listed type HT factory-built chimney.**

**High Temperature (H.T.) Chimney Standard UL-103-1985 (2100° F.) for the USA, and High Temperature (650°C) Standard ULC S-629 for Canada.**

The internal dimensions of the chimney connector and chimney must not be less than 6 inches diameter (or equivalent cross section), and should not be significantly larger than this. Too large a section will tend to allow the flue gases to cool excessively, causing sluggishness or unpredictability in the stove's performance.

**We recommend** the length of the chimney system should be at least 16 feet (not required) above the stove in normal domestic situations, measured from the flue collar to the top of the chimney.

Local conditions like for example - roof constructions, large trees nearby and high altitude, may influence the chimney draft and height. Therefore, contact the local professional chimney sweep or your Morsø dealer.

### Typical Factory-Built or Masonry Chimney Installations

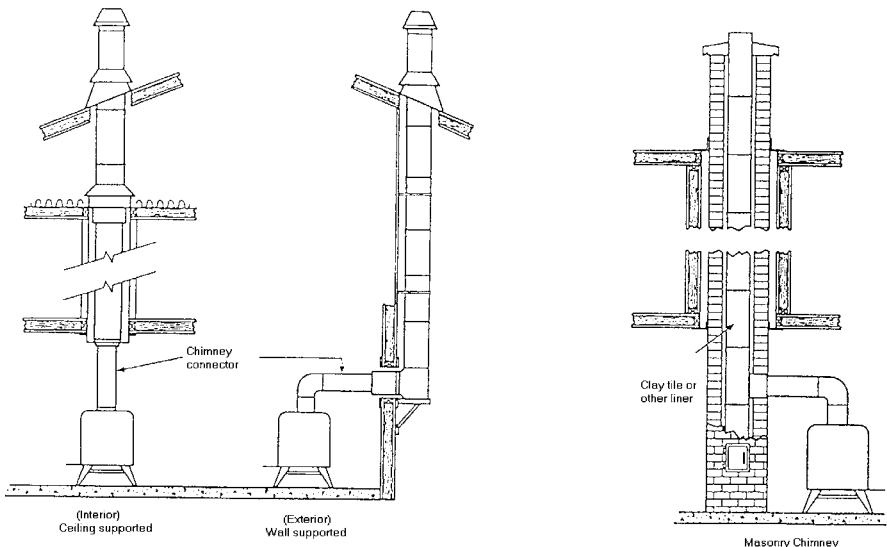

## 1.4 Flue Connection

The stove is supplied from the factory with a flue collar fitted to the top plate and a round blanking plate blocking off the rear flue exit (behind the rear shield plate).

Use a 24 MSG black or blue chimney connector or listed double wall chimney connector. Refer to local codes and the chimney manufacturer's instructions for precautions required for passing a chimney through a combustible wall or ceiling. Remember to secure the chimney connector with a minimum of three screws to the product and to each adjoining section.

The collar can be fitted to the rear outlet. Simply knock out the round panel on the rear heat shield plate to reveal the cast iron plate. Untwist the blanking plate and the flue collar and swap their positions. Re-secure by pushing down and tighten the enclosed screws.

Position the stove and connect to the flue system.

**Wear gloves and protective eyewear when drilling, cutting or joining sections of chimney connector**

## 1.5 Connection to the existing chimney

A chimney connector is the double-wall or single-wall pipe that connects the stove to the chimney. The chimney itself is the masonry or prefabricated structure that encloses the flue. Chimney connectors are used only to connect the stove to the chimney.

Double-wall connectors must be tested and listed for use with solid-fuel burning appliances. Single-wall connectors should be made of 24 gauge or heavier gauge steel. Do not use galvanized connector; it cannot withstand the high-temperatures that smoke and exhaust gases can reach, and may release toxic fumes under high heat. The connector must be 6 inches (150mm) in diameter.

**If possible, do not pass the chimney connector through a combustible wall or ceiling. If passage through a combustible wall is unavoidable, refer to the sections on Wall Pass-Throughs. Do not pass the connector through an attic, a closet or similar concealed space when installing the chimney connectors.**

It is important to keep the flue gases moving smoothly in the right direction. Do not vent into a large void at this location; rather form one continuous section all the way up. Use mild bends (e.g. 45° vs. 90°) rather than sharp angles where a change of direction is required. All parts of the venting must be accessible for cleaning purposes.

In horizontal runs of chimney, maintain a distance of 18 inches from the ceiling. Keep it as short and direct as possible, with no more than two 90 degree turns. Slope horizontal runs of connector upward 1/4 inch per foot (20 mm per metre) going from the stove toward the chimney. The recommended maximum length of a horizontal run is 3 feet (1 metre), and the total length should be no longer than 8 feet (2.5 metres).

Information on assembling and installing connectors is provided by the manufacturer's instructions exactly as you assemble the connector and attach it to the stove and chimney.

**Be sure the installed stove and chimney connector are correct distances from near by combustible materials. See the clearance paragraph page 8.**

## Chimney Connector Systems and Clearances from Combustible Walls for Residential Heating Appliances

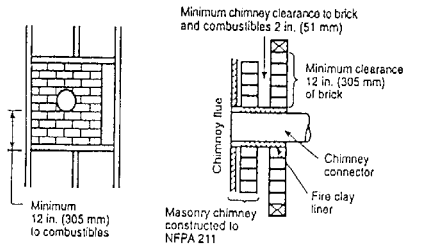

- A Minimum 3.5-in thick brick masonry all framed into combustible wall with a minimum of 12-in brick separation from clay liner to combustibles. The fireclay liner shall run from outer surface of brick wall to, but not beyond, the inner surface of chimney flue liner and shall be firmly cemented in place.

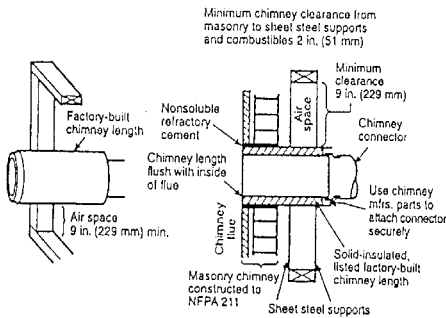

- B Solid-insulated, listed factory-built chimney length of the same inside diameter as the chimney connector and having 1-in. or more of insulation with a minimum 9-in. air space between the outer wall of the chimney length and combustibles.

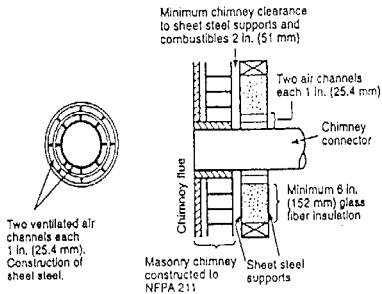

- C Sheet steel chimney connector, minimum 24 gauge in thickness, with a ventilated thimble, minimum 24 gauge in thickness, having two 1-in. air channels, separated from combustibles by a minimum of 6-in. of glass fiber insulation. Opening shall be covered, and thimble supported with a sheet steel support, minimum 24 gauge in thickness.

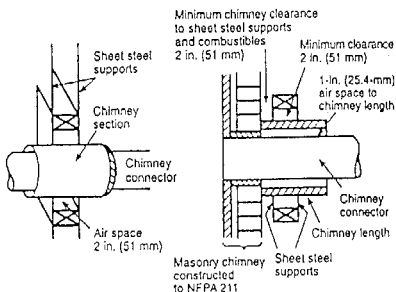

- D Solid insulated, listed factory-built chimney length with an inside diameter 2-in. larger than the chimney connector and having 1-in. or more of insulation, serving as a pass-through for a single wall sheet steel chimney connector of minimum 24 gauge thickness, with a minimum 2-in. air space between the outer wall of chimney section and combustibles. Minimum length of chimney section shall be 12-in. chimney section spaced 1-in. away from connector using sheet steel support plates on both ends of chimney section. Opening shall be covered, and chimney section supported on both sides with sheet steel supports securely fastened to wall surfaces of minimum 24 gauge thickness. Fasteners used to secure chimney section shall not penetrate chimney flue liner.

## 1.6 Positioning the stove

### Distance to walls and lintel

When the stove is positioned near combustible materials, observe all current local and national building regulations with regards to clearances. Whatever regulations apply to your area, do not in any case install the stove within 8 inches of combustible materials around the sides or 16 inches above the top of the stove (fireplace installations require greater clearances above the stove - see below in the clearance chart). These distances may need to be increased if the materials are sensitive to heat. Note also that wall paper and other decorative materials may become detached with the effects of heat and care should be taken to ensure that they do not fall towards the stove in such an event.

When the stove is positioned near non-combustible materials, a gap of 4 inches or more is recommended for cleaning purposes and to ensure that heat circulates around the stove and out into the room.

#### MINIMUM CLEARANCES TO COMBUSTIBLES: DEGAGEMENTS MINIMAUX AUX MATERIAUX COMBUSTIBLES:

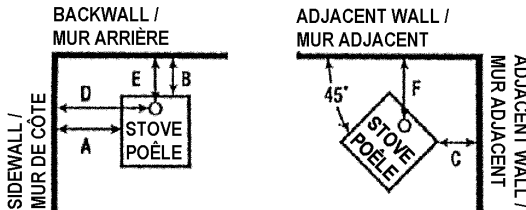

CLEARANCE REQUIREMENTS	STANDARD RESIDENTIAL INSTALLATION SINGLEWALL CONNECTOR	
	USA	CANADA
A. SIDEWALL TO UNIT	18"	460 mm.
B. BACKWALL TO UNIT	17"	430 mm.
C. CORNERWALL TO UNIT	13"	330 mm.
D. SIDEWALL TO CONNECTOR	30"	760 mm.
E. BACKWALL TO CONNECTOR	21"	535 mm.
F. CORNERWALL TO CONNECTOR	23"	585 mm.
G. UNIT TO CEILING	-	-
H. FLOOR TO CEILING	-	-

CLEARANCE REQUIREMENTS	STANDARD RESIDENTIAL INSTALLATION WITH CONNECTOR SHIELD	
	USA	CANADA
A. SIDEWALL TO UNIT	18"	510 mm.
B. BACKWALL TO UNIT	15"	380 mm.
C. CORNERWALL TO UNIT	13"	355 mm.
D. SIDEWALL TO CONNECTOR	-	-
E. BACKWALL TO CONNECTOR	-	-
F. CORNERWALL TO CONNECTOR	-	-
G. UNIT TO CEILING	-	-
H. FLOOR TO CEILING	-	-

ALCOVE INSTALLATION / INSTALLATION ALCOVE

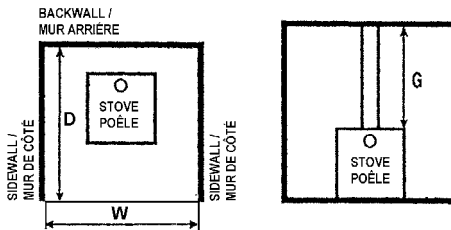

CLEARANCE REQUIREMENTS	ALCOVE INSTALLATION	
	USA	CANADA
W. MINIMUM ALCOVE WIDTH	65"	1650 mm.
D. MAXIMUM ALCOVE DEPTH	36"	915 mm.
G. ALCOVE CEILING ABOVE STOVE TOP	54"	1370 mm.

NON-COMBUSTIBLE FLOOR PROTECTOR:  
PROTECTEUR DE PLANCHER INCOMBUSTIBLE

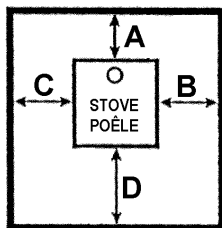

FLOOR PROTECTION MUST BE NON-COMBUSTIBLE MATERIAL, WITH AN R-VALUE OF 0.8 IT MUST EXTEND BENEATH HEATHER, AND TO THE FRONT/SIDES/REAR AS INDICATED.

LE PROTECTEUR DE PLANCHER DOIT ÊTRE D'UN MATÉRIEL INCOMBUSTIBLE (R=0.8). IL DOIT S'ÉTENDRE EN DESSOUS DE L'APPAREIL ET AU DEVANT, AUX CÔTÉS ET À L'ARRIÈRE DE L'APPAREIL COMME INDIQUÉ

FLOOR PROTECTION REQUIREMENTS	NON-COMBUSTIBLE MATERIALS BENEATH STOVE	
	USA	CANADA
A. EXTENDING DISTANCE, BACK	6"	200 mm.
B. EXTENDING DISTANCE, RIGHT SIDE	6"	200 mm.
C. EXTENDING DISTANCE, LEFT SIDE	16"	450 mm.
D. EXTENDING DISTANCE, FRONT	16"	450 mm.

**Distance to furniture**

The recommended minimum distance from stove to furniture is 30 inches. Note that some furniture is more easily affected by heat and may need to be moved to a greater distance. This is your responsibility.

In addition other combustible materials, away from the stove. In general, a distance of 30 inches must be maintained between the stove and moveable combustible item such as drying clothes, newspapers, firewood etc.

**Note:****Acid Protection**

If acid-washing the masonry around the stove, protect the stove surface with an acid-proof cover

**Fresh Air Inlet**

Unless there is deemed to be sufficient ambient leakage of air into the room via doorways, windows and the like, a dedicated fresh air inlet will be needed. This inlet should have 2 square inches (1250 square mm) of free air space. This is particularly important where the room is well sealed, or where an extractor hood or ventilation system disturbs the natural air pressure. Such an inlet should not be on a wall that is usually subject to negative pressure from normal wind pattern. Avoid placing the inlet directly across the room from the stove, thus causing a cold air draft.

## 2.0 Operation

### 2.1 Before you start firing

**For Use with Solid Wood Fuel Only. Do Not Overfire, If Heater or Chimney Connector Glows You Are Overfiring. Inspect and Clean Chimney Frequently. Under Certain Conditions of use creosote buildup may occur rapidly. Because of risk of smoke and flame spillage, operate only with door fully closed.**

**Caution:**

**Hot while in operation. Keep children, clothing and furniture away. Contact may cause skin burns.**

**Do not use chemicals or fluids to start the fire.**

**Do not burn garbage or flammable fluids.**

**Do not use gasoline, gasoline-type lantern fuel, kerosene, charcoal lighter or fluid or similar liquids to start or freshen up a fire in this heater. Keep all such liquids away from the heater while it is in use.**

### Choosing your fuel

All types of natural wood can be burned on your stove, but they must be well-seasoned and dry. Once the wood is cut to length, it should be split down middle - to suit the dimensions given below - to allow moisture to evaporate.

Cut the wood to a length of max 22 inches (56 cm) and approx. 3 to 3.5 inches (7-8 cm) in section. If you can weigh your wood, aim for around 2 lbs. For correct combustion and heat output, wood fuel should contain no more than 20% moisture; this can easily be checked by using the Morsø Moisture Meter (part # 62929900)

To naturally season wood fuel, stack and store it under cover in an airy location where fresh air can move through each piece. Some soft woods may take as little as one good summer to season whereas harder woods such as oak, maple, and elm may require seasoning up to 18 months. Avoid overly dry wood that is gray in color as under certain conditions it can cause performance problems, such as back-puffing and sluggishness. Well seasoned wood will be light to hold and will show signs of cracking from the center-out in the ends. If your wood spits or sizzles when burnt, and your stove's door glass persistently mists up, your wood is not properly seasoned. Never use drift wood (from the sea), whose salt content may cause corrosion, nor construction wood that may have been impregnated with chemicals.

### Starting the First Fire

**The initial fire should be small, so that the stove paint can cure and the main plates of the stove can settle into position. Some fumes will be given off by the paint. Ventilate the room during this phase.**

**The setting of the air control, lighting techniques and loading intervals will depend on chimney draft, the fuel used, the heat required and so on. Some basic techniques are outlined below.**

### In principle

Your stove is fitted with Primary and Secondary air inlets.

Primary Air is controlled using the lever situated under the ash lip of the stove. Moving the control lever into a downward position will open the air inlet and will allow a supply of preheated air to enter the firebox via the 'airwash' system situated inside the stove and the above glass.

Secondary Air is right to the firebox using specially designed baffle at the back of the firebox. The secondary air is injected into the flue gases both above and in front of the fire resulting in a cleaner, more efficient combustion process. The supply of secondary air is fixed open and is not adjustable.

For extra safety, your stove has been fitted with a removable handle. When not in use the handle can be stored using the lug by the right leg of the stove.

## 2.2 Lighting and loading intervals

When first lighting the stove, a large volume of air is needed. When the stove is cold, you should leave the door open an inch or two for the first few minutes and open the primary air supply completely. While the doors is open, do not leave the stove unattended.

To form a reasonable bed of ash on the floor of the stove, you should use 5-6 inches thickness (2-4 pound) of dry kindling at the initial lighting. Always maintain a 1-1.5 inch (2-3 cm) layer of ash on the floor of the combustion chamber at all other times.

### Step-by-step procedure

1. The air supply must be fully open.
2. Light the fire. An ember bed will quickly be formed by lighting with firelighters, morsø kindling bags or 7-10 pieces of twisted paper under the dry kindling wood (see above).
3. After lighting, partially close the doors, leaving them open an inch or two to allow in plenty of combustion air.
4. When the chimney is warmed through after 5-10 minutes, the doors should be closed. A suitable ember bed will be formed after a further 15-20 minutes.
5. When ready to reload, spread the ember across the firebox floor, bringing plenty towards the front of the stove.
6. Lay three pieces of wood (see dimensions above) onto the embers. Leave half an inch (1 cm) or more between each piece. When using 10 inches (25 cm) logs, place the ends of your logs towards the opening, but not too close to the front.



7. Close the door. Leave the primary air supply fully open.
8. After a few minutes, and adjust the primary air supply to suit your heating requirements.
9. Anticipate each refueling, remembering to add a modest layer of wood while there are still plenty of live embers, Repeat steps 5-8.

**Do not for any reason attempt to increase the firing of your heater by altering the air control adjustment range outlined in these directions.**

**Warning: Fireplace stoves must never be left unattended with doors open.**

**If the doors are left partly open, gas and flame may be drawn out of the fireplace stove opening, creating risks from both fire and smoke. We recommend that you fit a smoke detector in the room where the stove is installed.**

**DO NOT OVERFIRE THIS HEATER. Overfiring may cause a house fire, or can result in permanent damage to the stove. If any part of the stove glows, you are overfiring.**

The maximum recommended weight of wood fuel per load is 2.5 kg/h/5.5lbs (approx 3 split logs).

Under normal firing, the average flue temperature in the stove pipe, measured 20 cm above the stove, is approx. 300° C (550°F). The maximum flue temperature in the stove pipe must not exceed 450° C (750°F). If the flue temperature exceeds 450°C (750°F), it is considered as over firing and may cause premature wear and tear of the stove.

To help gauge the correct running temperature of your stove, we recommend you use the Morsø Flue Gas Thermometer (part # 62901200). The Flue Gas Thermometer magnetically attaches onto the stove pipe approx 20 cm (8") above the stove's top plate and measures the surface temperature of the stove pipe. Please see your authorized Morsø Dealer for availability.

### **Draft conditions**

If smoke or fumes come out of your stove when lightning up and reloading, or if the fire simply will not respond, a poor draft is almost certainly to blame. (In a very few cases, there may be insufficient fresh air getting into the room - see installation advice above). Take advice from your stove supplier on how best to upgrade your flue system to improve draft.

### Rules of woodburning

If you want less heat, put fewer logs on the stove and reduce the amount of air. It is still important to maintain a good layer of embers.

Less heat - less wood - less air

Greater heat - more wood - more air

Soot deposits will settle on the glass if the stove is run too slowly or if your wood is not well seasoned.

## 3.0 MAINTENANCE

**When performing maintenance on your stove, always protect yourself, using safety goggles and gloves.**

### 3.1 Exterior Maintenance

The stove surface is painted with heat-resistant Senotherm paint. It is best kept clean by vacuuming with a soft brush attachment or by wiping with a lint-free cloth.

Over a period of time, the painted surface may become slightly grey. A can of Morsø touch-up spray paint should be available from your stove supplier. This can be applied - in accordance with the instructions - in just a few minutes. When first firing after touching up, the stove will give off a slight smell as the paint cures. Make sure to ventilate the room well during this phase.

### 3.2 Internal maintenance

#### Glass

If the stove is generally run at the correct temperatures, there should be little or no dirt on the glass. If dirt does settle during lighting, most will burn off as temperatures increase. For heavier deposits that will not burn off, use morsø glass cleaner, applied when the glass is cold, in accordance with the instructions. Never use abrasive cleaners on the glass surface.

#### Reasons for dirty glass

- Fuel too wet
- Logs too large or not split
- Combustion temperatures too low

**Replace broken glass immediately.**

**Do not operate your stove if the glass in the door is damaged.**

If you need to replace the glass, it should be replaced with the high temperature ceramic glass supplied by Morsø, contact your Morsø dealer.

#### Installing the glass

**Never install the glass when the stove is in function.**

#### Ceramic glass replacement

Ceramic glass cannot be recycled because it has a higher melting point than ordinary glass. If ceramic glass is mixed with ordinary glass, the raw material is spoiled, and the reclaiming process may be halted. Take care that the oven-proof glass does not end up among ordinary recycled waste. That will be a great benefit to the environment.

Note: Should be handed in to a recycling station as ceramic glass.

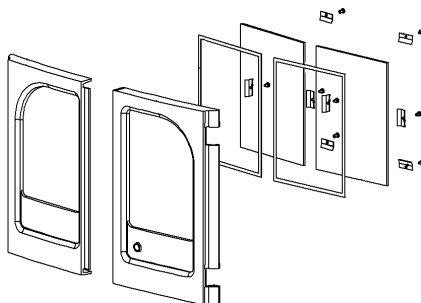

1. When you open the door, you will find two small M4 unbraco screws, one in each hinge. Unscrew the two screws, lift the door off the hinges and place it face down on a sheet of cardboard or other nonabrasive fabric.
2. Unscrew the 4 bolts that secure the glass. (In the event that a bolt sheers off when being unscrewed, remove the remaining body of the bolt by drilling down its centre with 1/8 inch high speed steel drill bit. Smaller drill bits may be successful, but do not use a larger bit. Make sure the bit stays away from the edges of the bolt - this may damage the thread in the cast iron).
3. Remove the old ceramic gaskets and clean up the surface underneath with wire wool or emery paper to remove loose particles.
4. Place the new gasket material in position around the perimeter of the window area, making sure to pinch them to the length in such a way that they make a continuous seal. Leave no gaps.
5. Place the new glass in position on the strips and screw home the fresh bolts and fitting by hand.
6. Finally, give each of the bolts an extra half turn or so. The glass should be held tight enough by that cleaning will not dislodge it. Do not over-tighten the bolts as this may put excessive pressure on the glass, resulting in cracking - important!

**To reduce the risk of breaking the glass, avoid striking the glass or slamming the door.**

### **Internal service parts**

The flame-path equipment - consisting of the ashpan, grate, firebricks, Cast iron fire plates, glass, baffle and flue collar - are subject to the extremes of heat produced by the fire. From time to time, one or other of these parts may need replacing as a matter of routine maintenance.

**NOTE: The flame-path equipment, the ceramic rope and the paint finish are not covered by guarantee.**

All of these service parts can be bought from your morsø dealer, and we recommend that damaged parts are replaced as soon as possible to avoid collateral damage.

Should the baffle be distorted by an overfire, the stove will still function, although its efficiency may be compromised. Replace it as soon as possible. The radiation shield on the back of the stove is first removed by loosening the 4 screws. The rear casing is removed (four bolts). Remove these and remove the 2 M8 bolts keeping the baffle plate. Withdraw the baffle from the firebox.

Before replacing the baffle, scrape out the old fire furnace and replace with new to make an effective seal.

### **Reasons for fast internal wear and tear**

Persistent heavy firing

Soot and ashes left to accumulate

### **Gasket**

The gasket around the perimeter of the doors may harden over a period of time. It should be replaced if it becomes difficult to close the doors or if air starts to leak in around the perimeter of the doors, causing the fire to become a little less controllable. A morsø rope gasket kit is available from your stove supplier.

### 3.3 Cleaning the Stove and the Flue

Check for soot above the baffle plate and around the flue outlet every month or so to start with. If the stove suddenly becomes sluggish, check for a soot fall around the flue collar or in the flue/chimney. - at least once a year. Inspect every month.

Clean the flue/chimney - all the way from the stove to the flue terminal point above the house.

A good routine is to clean the flue after each heating season in any case, and inspect prior to the season to ensure that bird's nests or other blockages have not occurred during the off season.

#### **Ash disposal**

Empty the ashpans on a daily basis or as needed. Ash allowed to build up towards the underside of the grate will trap heat and could cause premature failure of the grate.

#### **Empty the ashpan according to this procedure:**

Open the front doors, and use a shovel or poker to stir excess ash through the ash slots in the grate down into the ash pans. Remove the ash pans, making sure to keep it level.

Dispose the ash in a metal container with a tight fitting lid.

The closed container of ashes should be placed on a noncombustible floor or on the ground, well away from all combustible materials, pending final disposal. If the ashes are disposed of by burial in soil or otherwise locally dispersed, they should be retained in the closed container until all cinders have thoroughly cooled.

Return the ash pans to its original position in the stove, and close.

#### **Caution:**

**Never empty a stove in operation.**

**Never use your household or shop vacuum cleaner to remove ash from the stove; always remove and dispose of the ash properly.**

#### **Creosote - formation and need for removal**

When wood is burned slowly, it produces tar and other organic vapors, which combine with expelled moisture to form creosote. The creosote vapors condense in the relatively cool chimney flue of a slow-burning fire. As a result, creosote residue accumulates on the flue lining. When ignited this creosote makes an extremely hot fire. When burning wood, inspect the chimney connector periodically to determine if a creosote buildup has occurred.

#### **Chimney sweeping**

Inspect the system regularly during the heating season as part of a regular maintenance schedule. To inspect the chimney, let the stove cool completely. Then, using a mirror, sight up through the flue collar into the chimney flue. If you cannot inspect the flue system in this fashion, the stove must be disconnected to provide better viewing access.

Clean the chimney using a brush the same size and shape as the flue liner. Run the brush up and down the liner, causing any deposits to fall to the bottom of the chimney where they can be removed through the clean-out door.

Clean the chimney connector disconnecting the sections, taking them outside, and removing any deposits with a stiff wire brush. Reinstall the connector sections after cleaning, being sure to secure the joints between individual sections with sheet metal screws.

If you cannot inspect or clean the chimney yourself, contact your local Morsø Dealer or a professional chimney sweep.

**If you do experience a chimney fire, act promptly and:**

Close the air control.

Get everyone out of the house.

Call the Fire Department.

**Annual maintenance**

Before the heating season, perform a thorough cleaning, inspection and repair:

Thoroughly clean the chimney and chimney connector.

Inspect the chimney for damage and deterioration. Replace weak sections of prefabricated chimney. Have a mason make repairs to a masonry chimney.

Inspect the chimney connector and replace any damaged sections.

Check gasketing for wear or compression, and replace if necessary.

Check the glass for cracking; replace if needed.

Check door and handles for tightness. Adjust if needed.

### **3.4 Leaving the stove for extended periods**

**Important:**

If the stove is to be left unused for any period of time, clean it out thoroughly and leave the air control slightly open to allow airflow. Make sure that the flue does not allow rainwater to come anywhere near the stove; install a chimney cap, but do not block off the flue completely.

These measures should ensure there is a slight movement of air through the stove, and that the body of the stove remains dry, right into the corners.

Any ash left within an unfired stove can attract moisture like blotting paper. If moisture is allowed to settle within the stove, rust will form. Rust expands as it takes a grip. This can lead to undue pressure on the stove joints, and this in turn may result in damage to the stove.

NOTE: It is best to thoroughly clean the stove after the heating season has concluded. Adding a dessicant, such as kitter litter, into the ash pan helps absorb moisture during the summer months. Be sure to remove this prior to the heating season.

**Thank you for buying a morsø stove.**

We hope you have many years of carefree warmth in its company. Some initial experimentation with loading and running techniques will decide your normal routine. If you have any problems after this short learning phase, please refer to your stove dealer. Should they be unable to help for any reason, please contact us in writing at the address on the front of this publication.

# 3.5 Parts diagram for model Morsø 3600

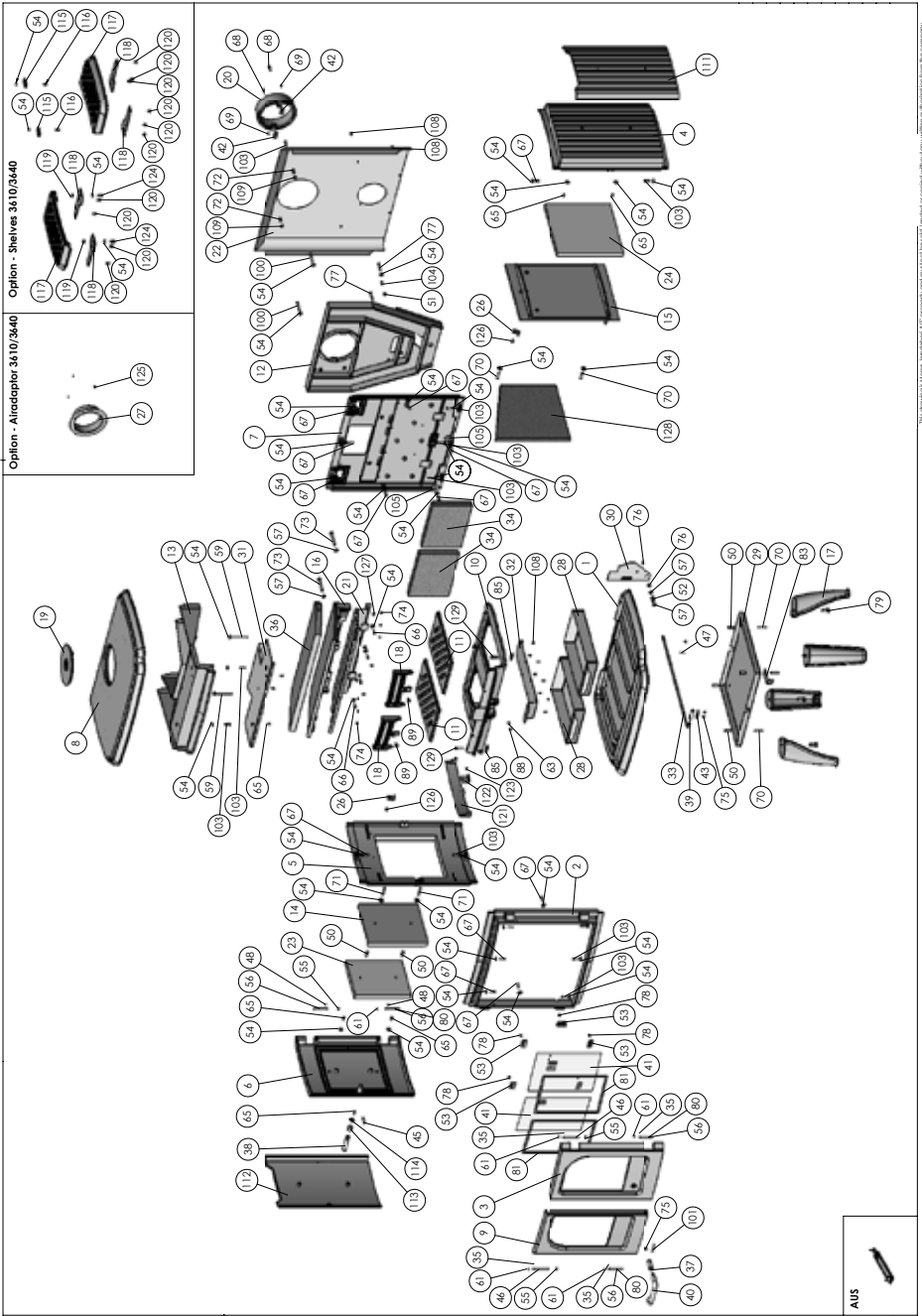

BILLY, BILLYSOKKEL, MORSØ, MORSØKAMIN, MORSØKAMIN MED UDSUG, TILBUDS OG COOKERS VEKSTUDIER - AFFILIATED INFORMATION FROM THE COMPANY.



### 3.6 Parts list for model Morsø 3600

Pos.No.	Parts	3610	3640
1	Base plate	443601XX	443601XX
2	Front frame	443602XX	443602XX
3	Door right	443603XX	443603XX
4	Side plate	443604XX	443631XX
5	Side frame	443605XX	443605XX
6	Door side	443606XX	443630XX
7	Inside rear plate	443607XX	443607XX
8	Top plate	443608XX	443608XX
9	Door left	443609XX	443609XX
10	Intermediate frame	44361000	44361000
11	Grate	34361100	34361100
12	Outside back plate	443612XX	443612XX
13	Inside top plate	44361300	44361300
14	Fire plate for side door	34361400	34361400
15	Fire plate for side plate	44361500	44361500
16	Baffle plate, cast iron	44361600	44361600
17	Leg	443617XX	443617XX
18	Front grate	44184900	44184900
19	Cover	442610XX	442610XX
20	Flue collar	443441XX	443441XX
21	Baffle plate, stainless	71360161	71360161
22	Convection rear plate	71360200	71360200
23	Insulation side door	79074900	79074900
24	Insulation side plate	79075000	79075000
26	Angle brace f. sideframe (Lefthand sidedoor)	71360461	71360461
27	Airadaptor	71360600	71360600
28	Ash tray	71360700	71360700
29	Radiant shielding, bottom	71360800	71360800
30	Draught control	71360900	71360900
31	Baffle plate, stainless, inside top	71361061	71361061
32	Plate for intermediate frame	71361161	71361161
33	Air inlet arm	713612XX	713612XX
34	Stone back	79360300	79360300
35	Screw	739405	739405
36	Insulation	79074800	79074800
37	Axis for handle	75362700	75362700
38	Axis for handle	75462700	75602700
39	Stainless handle for adjustment	75180400	75180400
40	Door handle, stainless steel	54186100	54186100
41	Ceramic glass	79360000	79360000
42	Fitting w. thread for flue collar	44256700	44256700
43	Assemble steel	71346500	71346500
44	Flat bar	545006	545006
45	Hinge pin	542056	542056
46	Hinge pin	545008	545008
47	Cotter pin	74202000	74202000
48	Screw	739408	739408
50	Distance tube	54313100	54313100

<b>Pos.No.</b>	<b>Parts</b>	<b>3610</b>	<b>3640</b>
51	Distance tube	545007	545007
52	Pressure spring, stainless	79048600	79048600
53	Glass fitting	54146361	54146361
54	Washer	791891	791891
55	Washer	746006	746006
56	Pin	74701000	74701000
57	Washer	736108	736108
59	Screw	731670	731670
61	Washer	791824	791824
63	Screw	73961700	73961700
65	Screw	731612	731612
66	Screw	731616	731616
67	Screw	731620	731620
68	Screw	743625	743625
69	Screw	791835	791835
70	Screw	731635	731635
71	Screw	74163504	74163504
72	Distance tube	545003	545003
73	Screw	731870	731870
74	Screw	74160804	74160804
75	Screw	731608	731608
76	Nuts	735008	735008
77	Screw	731645	731645
78	Screw	73850800	73850800
79	Screw	731125	731125
81	Tightening tape	79074500	79074500
83	Hanging for handle	54185800	54185800
85	Fitting for Intermediate frame	541831	541831
88	Nut	73500601	73500601
89	Screw	73861300	73861300
100	Screw	731650	731650
101	Hinge pin	541082	541082
103	Screw	731625	731625
104	Screw	743616	743616
105	Washer	79189300	79189300
107	Washer	736106	736106
108	Screw	731610	731610
109	Washer	746206	746206
111	Konvection Side Plate right	-	443621xx
112	Konvection Side Plate left	-	443622xx
113	Distance tube	-	54362500
114	Distance tube	-	54362600
115	Fitting Plate for Shelve	-	713622xx
116	Screw	-	73861100
121	Front Grate	443624xx	443624xx
122	Fitting for Front Grate Door side	54362861	54362861
123	Screw	74340804	74340804
125	Screw	79183300	79183300
126	Screw	73861100	73861100
127	Screw	73861900	73861900
128	Stone side	79360400	79360400
129	Screw	73863100	73863100